

These commodities/technical data are controlled for export by the U.S. State Department. They may not be transferred, transshipped on a noncontinuous voyage, or otherwise be disposed of outside of the United States, either in their original form or after being incorporated into other end-items, without the prior written approval of the U.S. Department of State.

REVISIONS				
LTR	DESCRIPTION	ECN	DATE	APPROVED
A	PRODUCTION RELEASE	DD39312	10/1/09	MPD



DRAWN	DAW	DATE	8/28/09
CHECKED	DPM	DATE	10/1/09
ENGRG APPD	MTH	DATE	10/2/09
PROJ APPD	MPD	DATE	10/1/09
APPROVED			

Transtector Systems, Inc.
 10701 Airport Road, Hayden, ID 83835
 800.882.9110 208.772.8515 www.transtector.com

TITLE

Specification I2R 120/240 RR
120V AC Split Phase Surge Protector

NOTICE:
 THE INFORMATION AND DESIGN IN THIS DOCUMENT IS THE PROPERTY OF TRANSTECTOR SYSTEMS. ALL RIGHTS RESERVED.

DOCUMENT NUMBER	1400-677	REV	A
CAGE	30992	PAGE	1 of 9

GENERAL MODEL DESCRIPTION

I2R 120/240 RR AC Power Surge Protector

The I2R 120/240 RR surge protection device was designed to safely protect bungalow service panels and equipment. The I2R 120/240 RR utilizes a combination of silicon avalanche suppressor diode (SASD) and metal oxide varistor (MOV) technologies to achieve a balance of very low voltage protection levels at high induced surge currents. The surge protector is constructed in such a manner as to effectively provide primary protection of sensitive electronic equipment with high endurance SASD and MOV elements. Protection is maintained using touch safe surge rated fusing for direct buss connection. Direct buss connection allows the suppression device to be installed without a circuit breaker that can limit the suppression device (see AREMA paper “Cause & Effect of AC Breaker Tripping Investigation”). The surge rated fusing elements are capable of passing high current transients, providing superior surge suppression, but still provide safe & reliable protection under fault conditions. The fusing elements are held in a touch safe replaceable housing with visual status/indicators. A non metallic enclosure has four sided access through multiple pre-formed drill/cut conduit mounting holes. The design is modular based using DIN mounted surge assemblies protected against overload by easily replaceable touch safe surge rated fusing. Visual status indicators are easily checked by viewing through the clear front panel window, and are safely accessed for closer inspection by opening the hinged front panel. In addition to the visual status indicators, dry contact switches are located inside the enclosure on both SASD suppressors for connection to auxiliary indicator or alarm circuits.

1.0 SPECIFICATION/PERFORMANCE

1.1. Continuous Operating Electrical Specifications:

- 1.1.1. Nominal Operating Voltage: 120/240V
- 1.1.2. Frequency Range: 50/60 Hz
- 1.1.3. Phases: Split Phase
- 1.1.4. Wire Configuration: L-N, L1-L2-N
- 1.1.5. Maximum Continuous Operating Voltage (MCOV): 145VAC L-N
- 1.1.6. Dry Contact Ratings:5A/75VDC, 0.1A/250VDC, .5A/250VAC
- 1.1.7. Contact Isolation: 3750VAC

1.2. Enclosure Mechanical Specifications:

- 1.2.1. Enclosure Type: Indoor Dry Location, Screw Access
- 1.2.2. Enclosure Material: High Density Plastic
- 1.2.3. Enclosure Dimensions: 8.66"x8.07"x5.51" (220mmx205mmx140mm)
- 1.2.4. Weight, Split Phase, Fully Configured: 3.8lb (1.7kg)

1.3. Surge Specifications:

- 1.3.1. Surge Protection.....370V @ 500A 8/20µs
Testing Per ANSI/IEEE C62.45 2002 Power Applied.....400V @ 3kA 8/20us
- 1.3.2. Suppressor (Max. Design Limit Per Phase):..... 45kA
- 1.3.3. Response Time (Max.): 1ns
- 1.3.4. Standby Power (Max.):0.25 W

1.4. Electrical Connections/Installation Requirements:

- 1.4.1. AC Power Wire Size:..... #10AWG (2.59mm)
- 1.4.2. Wire Connection Length:..... 18 inches (45 cm) Maximum
- 1.4.3. Wire Connections:.....Phase/Neutral
- 1.4.4. Isolated Relay Terminals:.....3-Pin connector, #22 – 14 AWG (2mm max)

2.0 ENVIRONMENTAL

- 2.1. Operating Temperature:.....-40C to +85C
- 2.2. Storage Temperature:-40C to +85C
- 2.3. Relative Humidity: 100% non-condensing
- 2.4. Ventilation:not required, direct sun loading is not recommended

3.0 STATUS INDICATOR

- 3.1 The red indicator on the top surface of each module indicates suppressor status. This indicator will protrude from the top of the module .34” [8.6mm] when the module has failed. Should the module fail, contact Transtector or a certified Transtector distributor immediately (1-208-772-8515).

Warning: Do not perform any maintenance, make any adjustments, or replace any components inside the enclosure with the power supply turned on. To avoid injury, always turn the main power supply off before performing maintenance and/or testing.

- 3.2 Contacts are provided to monitor the status of the suppressor. A three terminal “Euro” style plug-in connector provides access to the “Form C” contacts. The contacts will change state in the event of power failure or the loss of a module.

4.0 INSTALLATION INSTRUCTIONS

Mechanical mounting requirements for wall space reference Figure 1. Remove top cover by loosening four built-in plastic attachment screws located at each corner (Reference Figure 2). Select and remove plastic from desired conduit hole, attach conduit if used and confirm wiring fit. Secure back panel to a flat surface through the four molded mounting locations located on the inside the enclosure base using four fasteners. Recommend #10 self tapping screws (not included) (Reference Figure 3). Connect one black wire from suppressor to Ø1 phase then connect the other black wire to the Ø2 phase. Connect white suppressor wire to the panel neutral connection ensuring all wires are as short as possible. (Reference Figure 4 for Wiring Diagram). Confirm all connections are routed as smoothly as possible with no extra wire looped inside the enclosure. If required attach dry contact wiring with insulation rated for minimum 600VAC to desired alarm system if routed through the same conduit as the suppression wires (Reference Figure 5 for proper location of alarm contacts and wiring locations). Replace top cover tightening four cover retaining screws approx 1-3/4 turns.

Mechanical Outline:

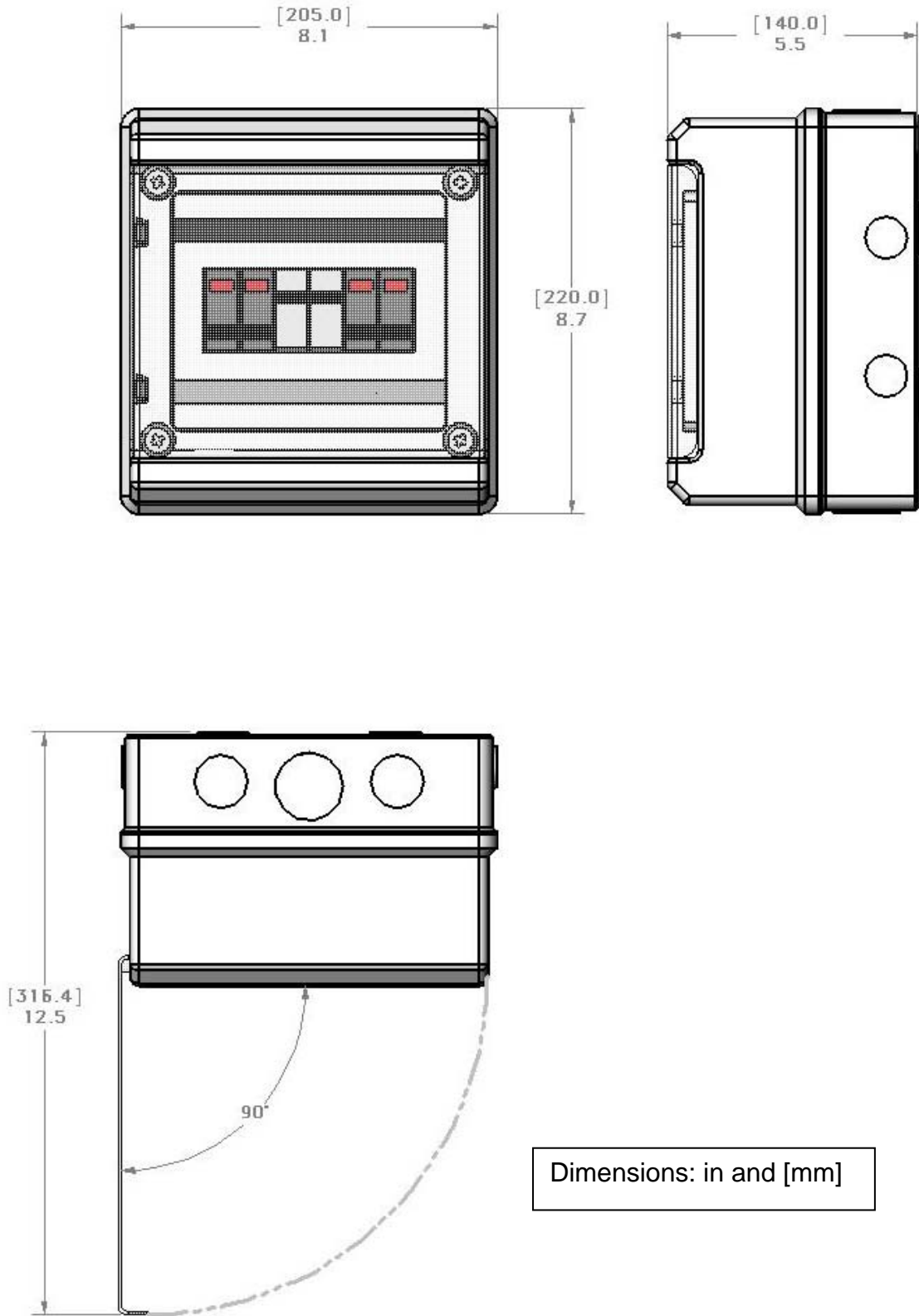

Figure 1: Mechanical Outline

Disassembly for Installation:

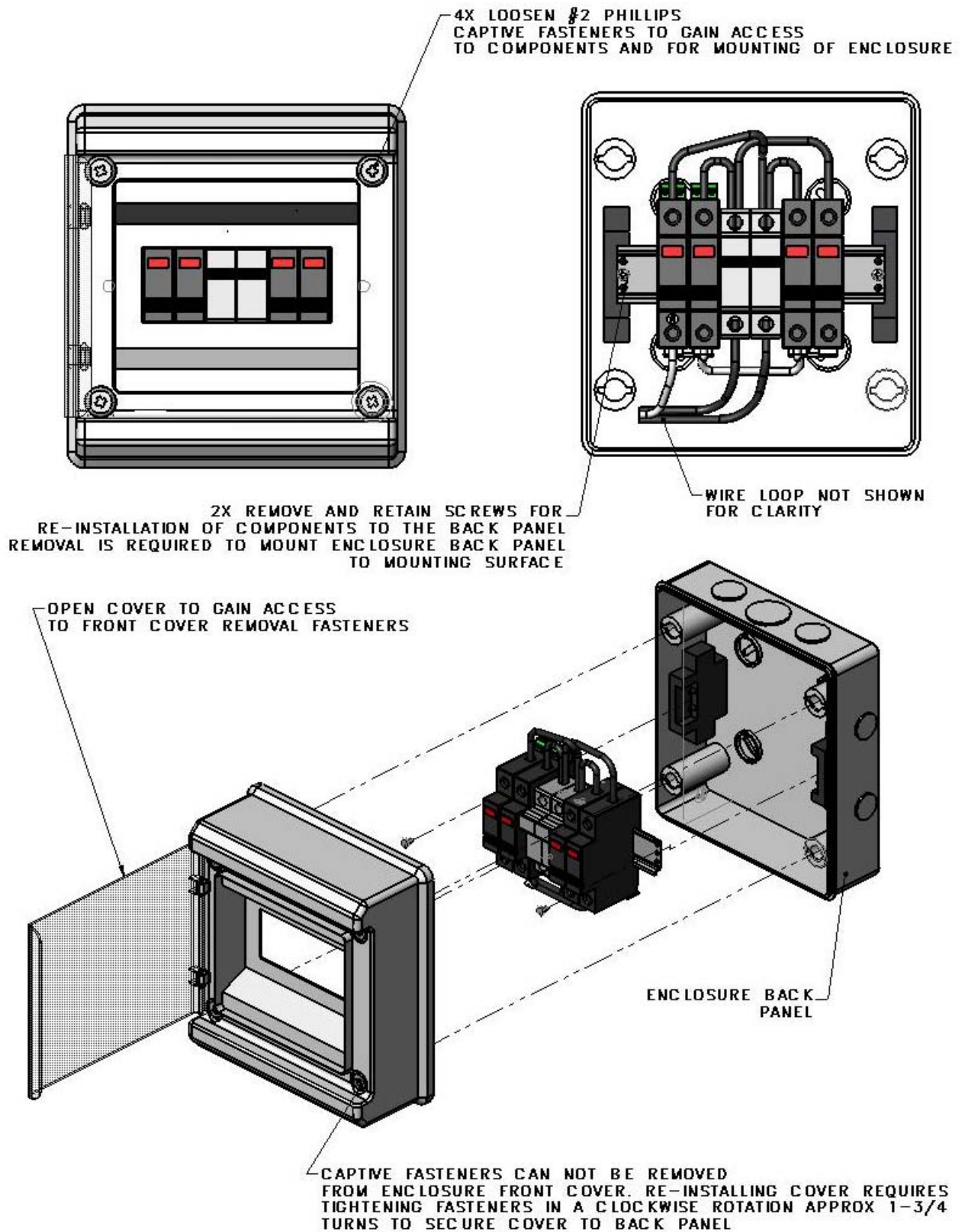

Figure 2: Disassembly for Installation

Installation of Back Panel to Mounting Panel:

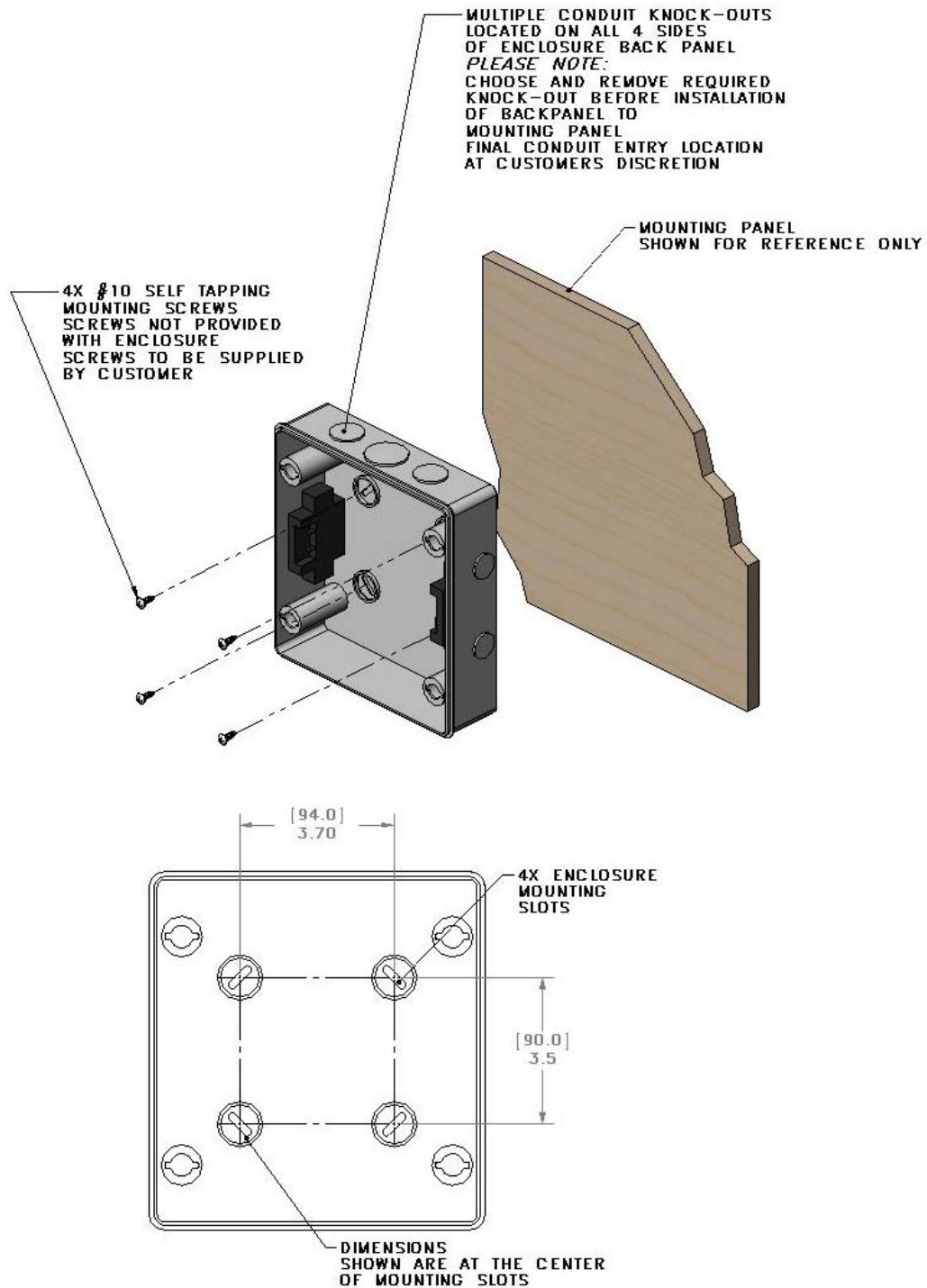

Figure 3: Installation of Back Panel to Mounting Panel

Wiring Diagram:

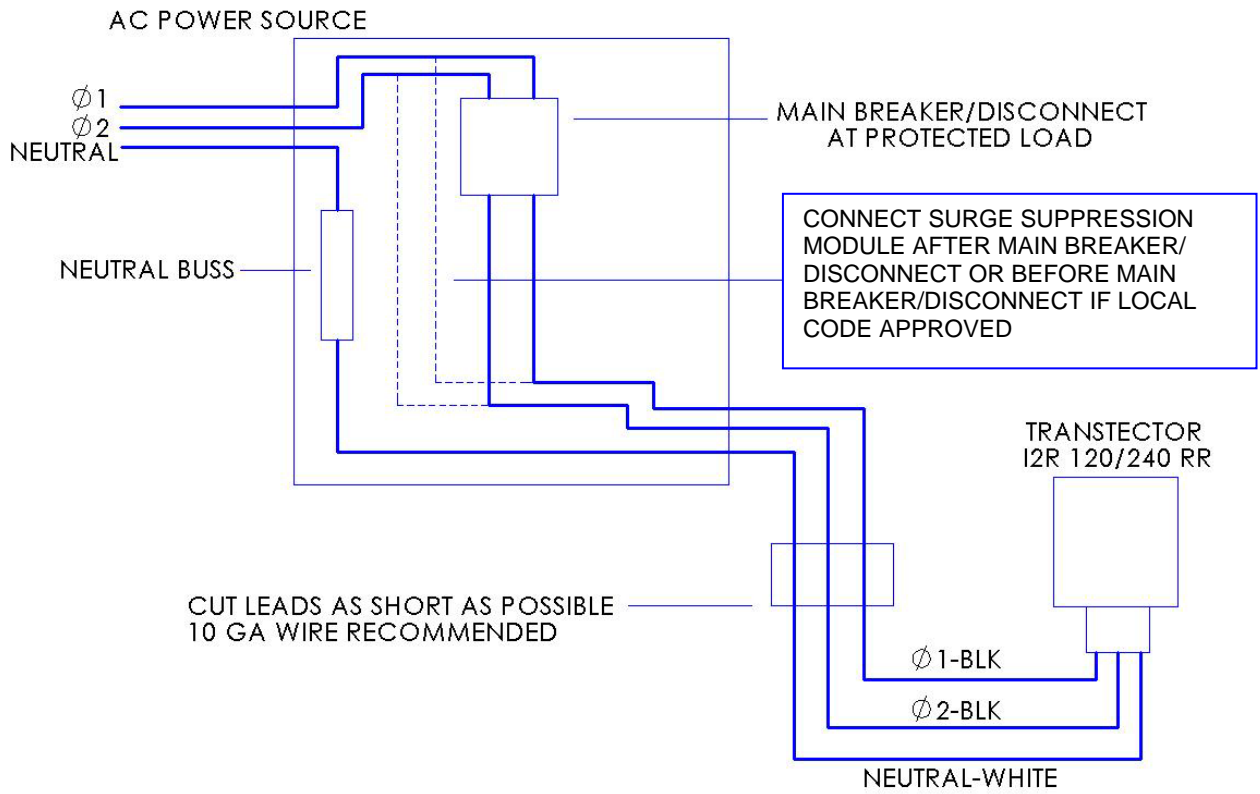

Figure 4: Wiring Diagram

Dry Contact Wiring:

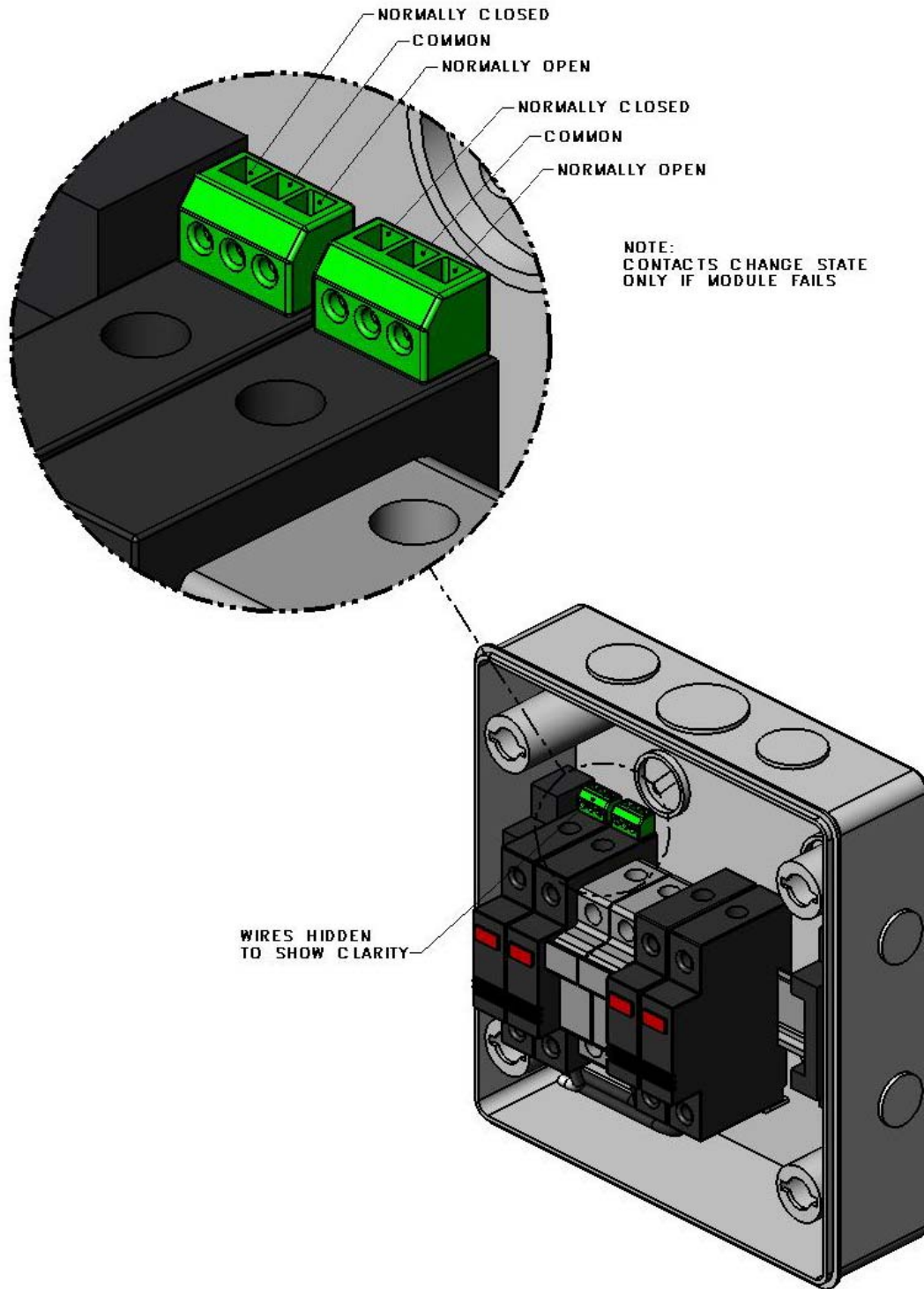

Figure 5: Dry Contact Wiring